

LT110 – Laser Ride Height Sensor



The LT110 is a time of flight distance measurement sensor ideally suited for ride height measurement applications. Standard measurement ranges of 0-40” and 0-80” mean that even large wheel stands, or jumps can be accurately measured. High ambient light immunity means that even measuring in direct sunlight is not an issue. Using a standard M12 connector the LT110 can be powered with 5-36V and provides a 0-5V output to interface with the vehicle ECU or data logger. Standard output ranges of 0-40” and 0-80” are available.

Item	Value	Units
Supply Voltage	5-36	Volts
Supply Current	<200	mA
Distance Output Signal	0-5	Volts
Distance Sensing Range	0-39.4	Inches
Temperature Output Signal	0-5	Volts
Suggested Sample Frequency	>100	Hz
Mounting Screw	#6-32	-

Notes:

- Distance output is linear 0-5V to 0-39.4inches (0-100cm). At 4.8V (37.8inches) unit will clip output.
- The status LED on top of the unit, and the output voltage will operate as following:
 - On power up LED will flash orange and then go solid blue.
 - Normal operation: solid blue LED, output voltage 0-5V linear with distance.
 - Error from inability to detect surface or out of range: solid orange LED, output voltage 5V.
 - Low supply voltage: continuously alternating orange/blue LED, output voltage 0V.
- If unit is unable to detect a highly reflective surface, it may be beneficial to angle the unit slightly relative to the surface, rather than perpendicular.
- Distance sensor lens material is acrylic. Do not use acetone, brake cleaner, etc. to clean as this will damage the lens and affect sensor performance. Clean distance sensor and temperature sensor lenses with microfiber or other soft cloth to keep dirt and debris from affecting performance.
- Distance sensor has blind zone of approximately 4 Inches. This means that objects closer than this cannot be measured accurately.
- It is recommended, but not necessary to mount sensor with logo on the sensor mounted fore-aft. i.e. Logo on sensor body pointed forward or backward on the car.
- Removable thread locking compound on the mounting hardware is generally a good idea, especially in high vibration environments.

Pinout as viewed from top of sensor:

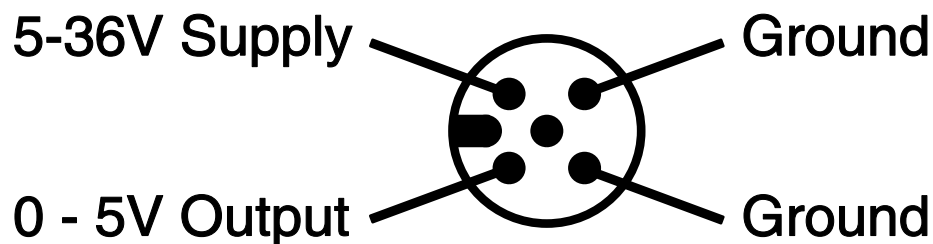

5-36V Supply - Brown

0 - 5V Output - White

Ground - Blue

Ground - Black

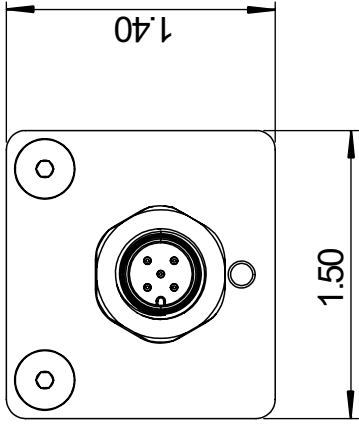
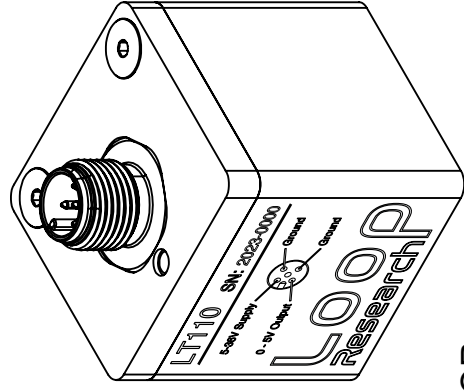

M12 5 PIN
CONNECTOR

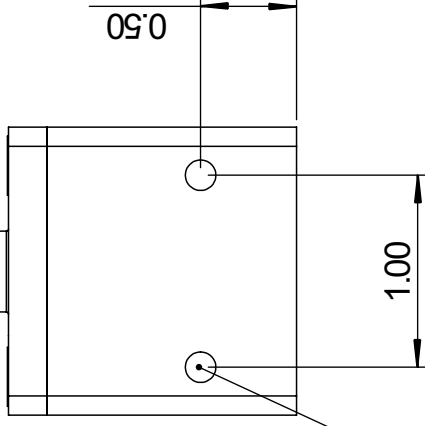
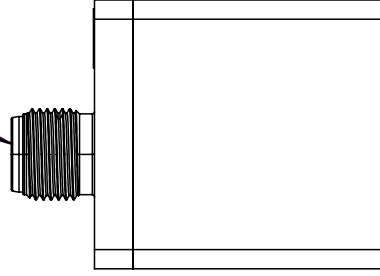
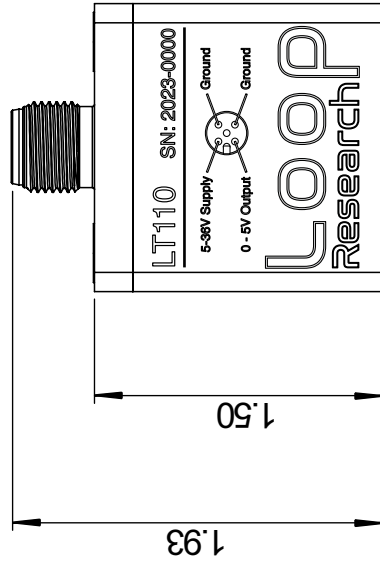

#6-32
▽ 0.35
2 PLACES

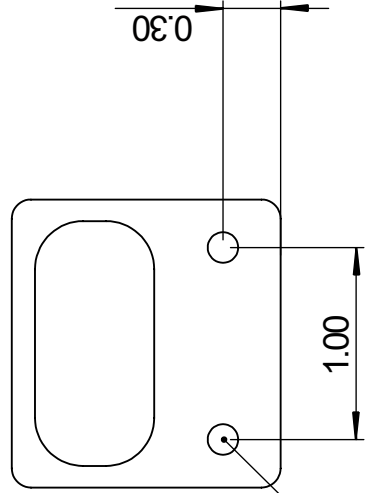

#6-32
▽ 0.35
2 PLACES

LOOP
Research